

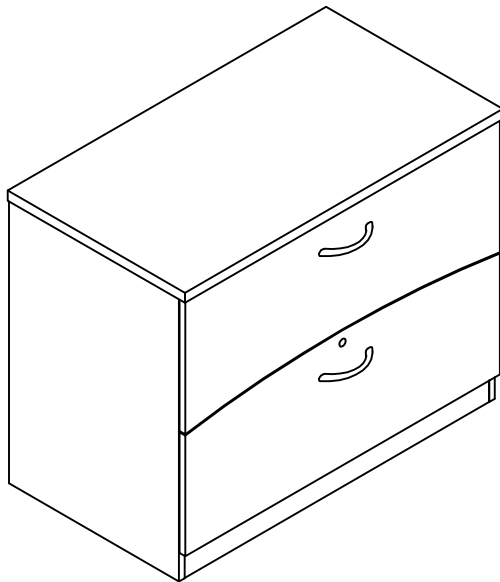





Brighton Series™
Freestanding Lateral file
Model No. BTFLF36



ASSEMBLY INSTRUCTIONS
CALL 1-800-822-8037 FOR ASSISTANCE

PARTS LIST

Name	Part	Qty.	Spare Qty	Name	Part	Qty.	Spare Qty
A	 REALBY026 Handle 128mm	8		D	 REALBY028 Wrench	1	
B	 REALBY027 M4 x 22mm	4			 KEYS		
C	 REALBY012 M4 x 35mm	4	1		 BTFLFHB		

Items with HB are in hardware box.

**Denotes Color Code

- 2** Install Handles (A) on to drawer fronts using Screws (B).

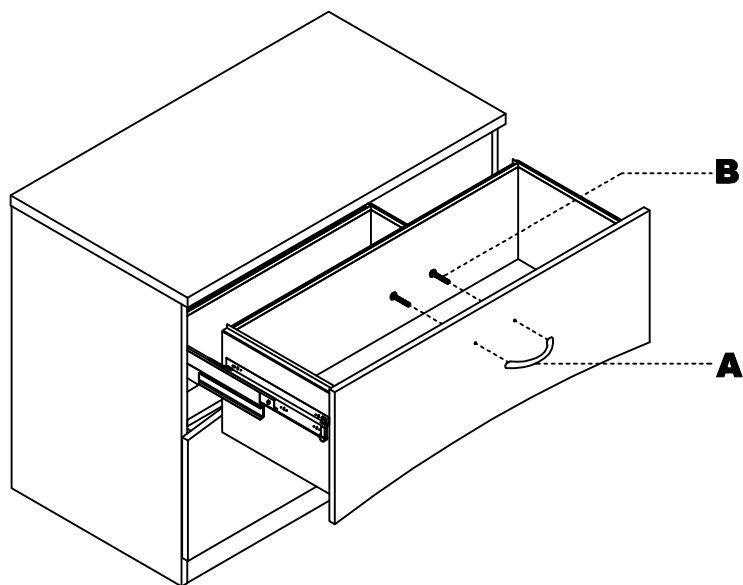

2

Optional Steps for using Lateral File under a Desk or Credenza.

- 2** Remove top drawer from Lateral File by depressing the plastic tabs and pulling the drawer out of the cabinet.

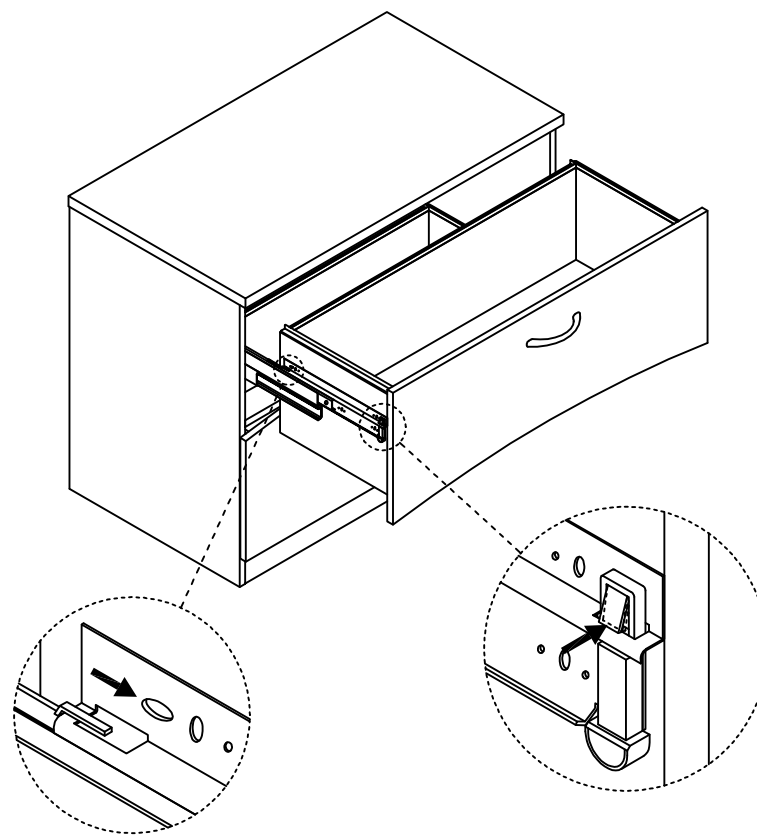

3

- 3** Loosen the Cams in the top of the side panels and back. Lift the Top off the cabinet.

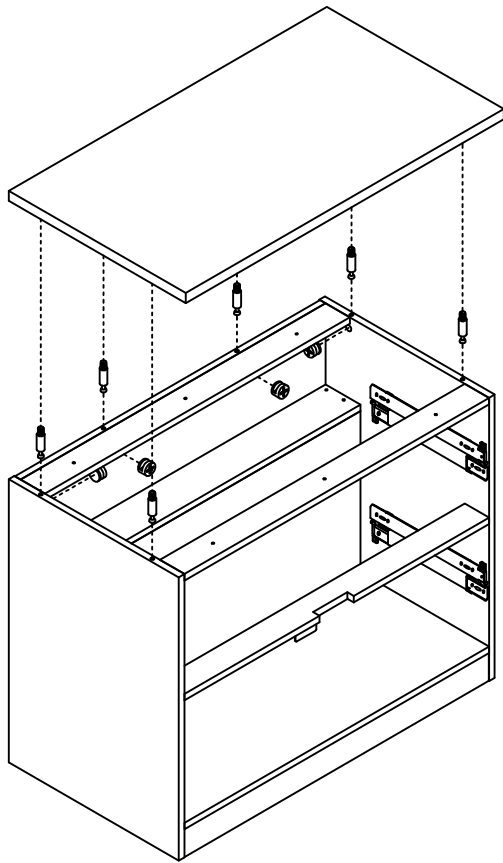

4

- 4** Slide Cabinet under Desk or Credenza and fasten to underside of Desk or Credenzaz Top using Screws (C) through crossmembers in top of Cabinet.

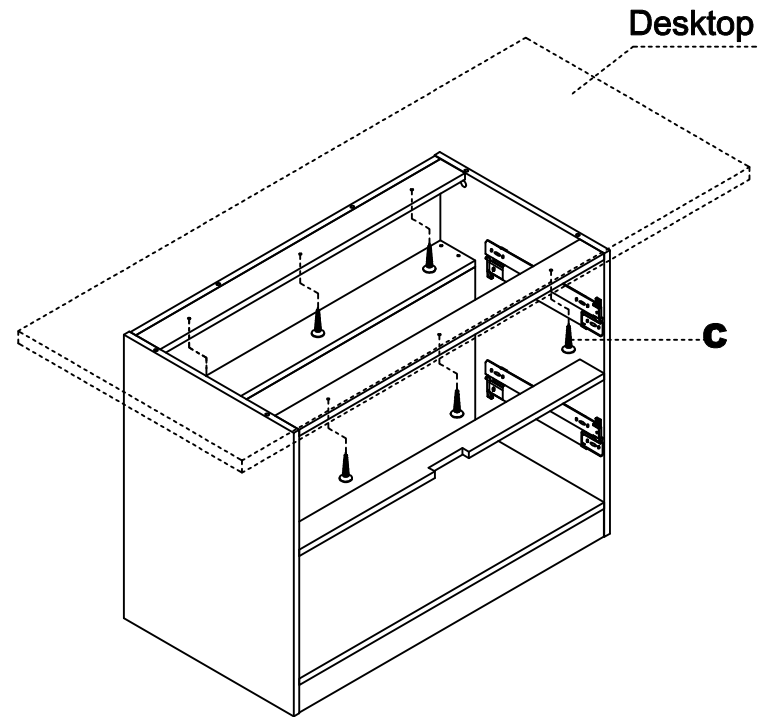

5

No filing bars required for Letter sized hanging folders.

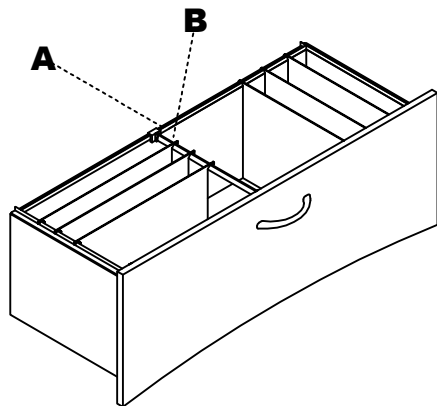
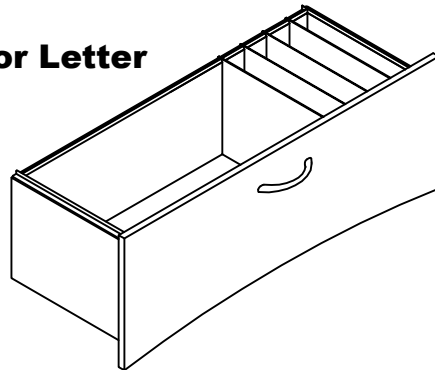



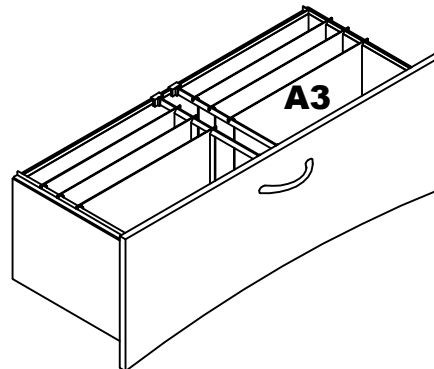









One filing bar for combination of Letter and Legal sized hanging folders.

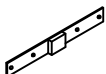

Two filing bars for Legal sized hanging folders.

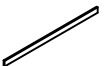
6

Pre-Installed Replacement Parts List

Part	Included Qty.	Part	Included Qty.
 REALBY039 Drawer Slide 14" - Pair	2	 REALBY013 M6 x 20mm	4
 REALBY042 Lock	1	 REALBY008** Hole Cap 15mm	4
 REALBY043 Lockpin	1	 REALBY034 Bumper	8
 REALBY044 Lockpin	1	 REALBY029 File Bar Clip	8
 REALBY048 Drawer Interlock	1	 REALBY031 File Bar 293 x 15 x 3mm	4
 REALBY018 Leveler (50H)	4	 BTF36DF** Drawer Fronts, Set of 2	1
 REALBY009 M3.5 x 14mm Black	74		

**Denotes Color Code

7