

CSII Furniture Specifications Guide

Use this worksheet to help us specify a CSII furniture plan that fits your individual needs and applications.

Provide layout with dimensions.

- Electronic Floorplan (*Acceptable formats*)
 - Adobe
 - AutoCAD
 - Giza
- Sketch (use grid below)

Include building features i.e. Doorways, Corridors, Electrical Outlets, Data Ports, Raceways, Lights, Heating Ducts etc.

How many people need to work in this space? _____

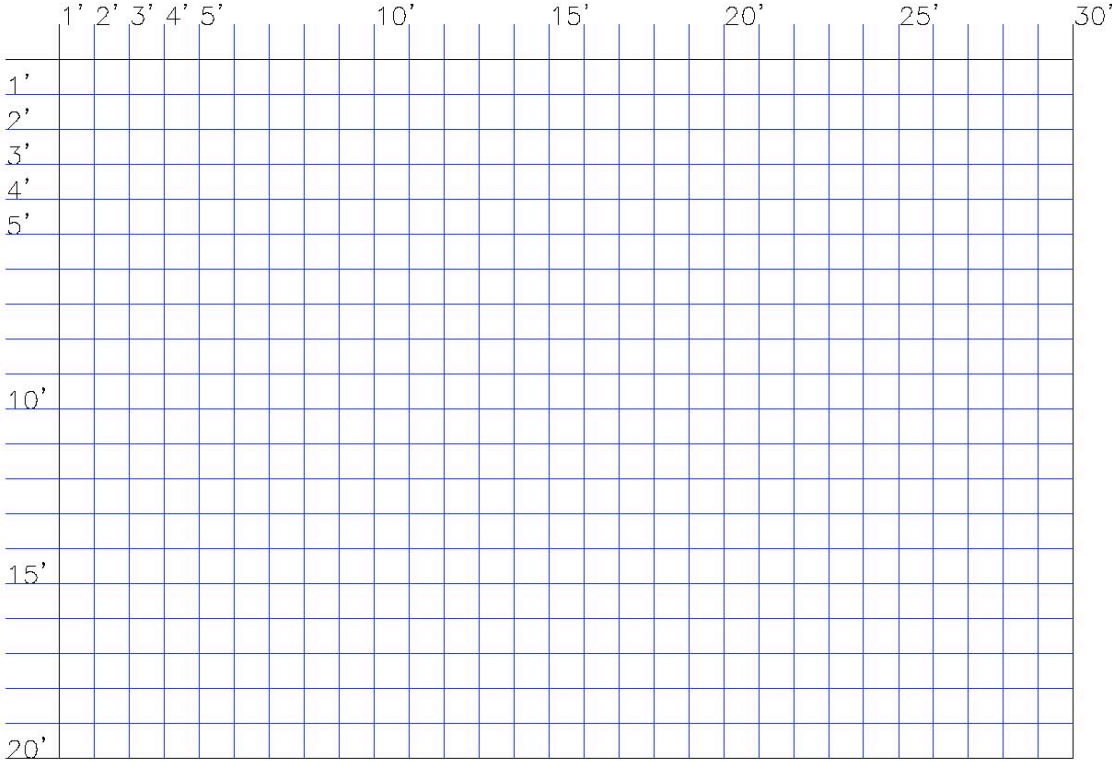

Workspace Requirements

How much workspace is required for each user?

- User #1: _____ User #5: _____ User #9: _____
 User #2: _____ User #6: _____ User #10: _____
 User #3: _____ User #7: _____ User #11: _____
 User #4: _____ User #8: _____ User #12: _____

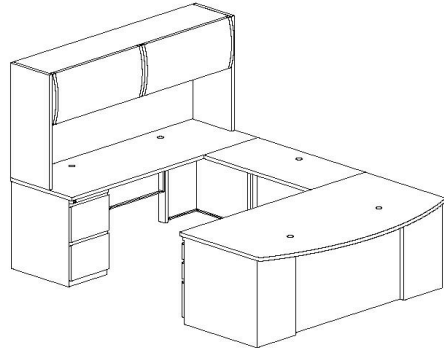

Modular Clustering Preferences

- Cluster of four
- Cluster of six
- Cluster of eight
- Straight row

Needed Features (What does each user require to perform their task?)

Desking

<u>QTY.</u>	<u>USER #</u>	<u>QTY.</u>	<u>USER #</u>
___	___	___	___
___	___	___	___
___	___	___	___
___	___	___	___
___	___	___	___
___	___	___	___
___	___	___	___
___	___	___	___
___	___	___	___
___	___	___	___

*Modesty panel for bridge? None 2/3 Full

Filing & Storage

<u>QTY.</u>	<u>USER #</u>	or	<u>QTY.</u>	<u>USER #</u>
___	___		___	___
___	___		___	___
___	___		___	___
___	___		___	___
___	___		___	___

Keyed Alike Tumblers Yes No

Overhead Storage

- Flipper Door Overhead
- Flipper Door with Soft Close
- Open Shelf Overhead
- Optional Fabric Tack Panel
- Task Lighting

Keyed Alike Tumblers Yes No

Keyboard Option

- Yes No
- How many in all? _____

Pencil Drawer

- Yes No
- How many in all? _____

CPU Storage

Dolly
How many in all? _____

CPU Under Surface Holder
How many in all? _____

Privacy Panels

Complete Privacy Combo/Step
*If not specified, we will quote for complete privacy on all stations.
Add to sketch or describe in writing...*

Additional Work Areas

Printer Meeting
 Copier Training
 Collating Conference
 High Density Filing Mailroom
 Network Products

For assistance please see the Design Services section of our website @ www.mayline.com

Other Details

Are there any other special requirements that should be known prior to designing this application?

For assistance, please call Mayline at 800-822-8037.
An electronic form is available at <http://www.mayline.com>

Please submit this form to the Mayline Company by e-mail (spaceplanning@mayline.com) or fax (920-208-7970). We will then reply within three business days with a drawing of your workstation with bill of materials and quote at suggested list price.

Name: _____
Company / Organization: _____
Address: _____
City: _____ State: _____ Zip: _____
Telephone: _____ Fax: _____
E-Mail: _____
Are you a (an) Dealer End user
If dealer, please include end user / project name: _____

